



All Natural  
Land Care Supplies

# BOBOLATOR COMPOST TEA BREWER MANUAL (Makes 25 - 250 gallon batches)

Unlike the tea that is served with crumpets, compost tea is not steeped in hot water until the color of the water darkens. Cool to tepid, non-chlorinated, and highly oxygenated water is used. Chlorine kills microorganisms and is commonly used in municipal water systems. If chlorinated water must be used, it should be aerated with the brewer's air pump for one hour before brewing tea.



Aerate water for one hour to drive off chlorine.

**OPERATION:** The brewer comes pre-assembled (except for connecting the pump) and ready to install in your tank as shown in the drawing. Just hang the brewer by the hook on the side of your tank and connect the air line to the air pump. Do not over or under fill the barrel (see drawing).

**LOADING AND BREWING:** Add nutrients and compost (see recipes) to the top of the brewer. **Use 65 - 80° F water.** Microbes grow too slowly in cold water and won't like it much over 80° either. Brew for 18 to 24 hours. After 18 hours, the bacterial content of the tea may increase while the fungal content may decrease. Brewing longer than 24 hours may reduce dissolved oxygen levels to below acceptable levels. If only cold water (55 - 65°) is available, brew for 30 to 36 hours or use a tank heater to warm the water. If water is warmer than ideal (75 - 85°) 18 hour brew time may be appropriate. Allowing the brewer to continue operating beyond prescribed time period may alter the microbe content.



Pour compost and nutrients into the top of the brewer.

After brewer is removed, aeration should continue with the aeration tube until application time.

**CLEANUP:** Remove the clamp and screen (see parts list) from the chamber and rinse with a garden hose. If necessary, use a chlorine bleach type cleaner and sponge. Avoid using abrasive cleaners. They will roughen the inside surface and make it more difficult to clean in the future. Clean the tank in the same manner. Brewer can be reassembled wet or dry. Lay screen evenly over the chamber windows and press clamp onto chamber. Be sure the clamp is all the way down.

**FOAM:** One of the features of a good brew is the creation of foam. Sometimes enough foam is created to push the cap off the chamber and move compost from the chamber into the tank. Lightly coating the upper 6 inches of the brewer's inside walls with corn oil before you start will prevent foam from climbing out of the brewer.

**IMPORTANT POINTS TO REMEMBER:** The desired microbes proliferated in compost tea are aerobic and they depend on dissolved oxygen. If dissolved oxygen levels drop below 5.7 µg/ml, undesirable, anaerobic organisms may develop. To prevent this from happening without the benefit of an expensive dissolved oxygen sensor, the following important points should be remembered: Do not overload the brew with compost or nutrients (follow the recipes); do not use water that is too warm; do not brew beyond the recommended cycle time; and do not shut off aeration until you are ready to apply the tea. If only cold water is available, use a tank heater to increase water temperature to 65° - 80° F.

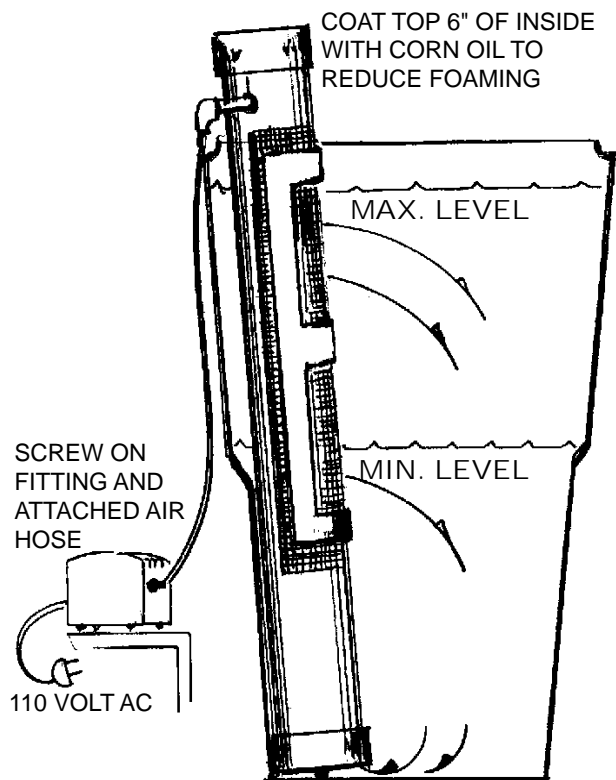

## COMPOST TEA BREWER PARTS LIST

- 1 CHAMBER
- 2 CLAMP
- 3 SCREEN
- 4 AERATION TUBE ASSEMBLY
- 5 AERATION HOSE
- 6 CAP
- 7 PUMP AND HOSE FITTING
- 8 MEASURING SCOOP
- 9 HOOK AND BOLT (NOT SHOWN)
- 10 INTAKE AND BOLT

## AVAILABLE ACCESSORIES (NOT SHOWN)

- 1 TANK THERMOMETER
- 2 TANK HEATER
- 3 DR. ELAINE INGHAM'S COMPOST TEA BREWING MANUAL
- 4 TEA COMPOST, TEA MINERALS, BACTERIA AND FUNGI BOOSTERS.

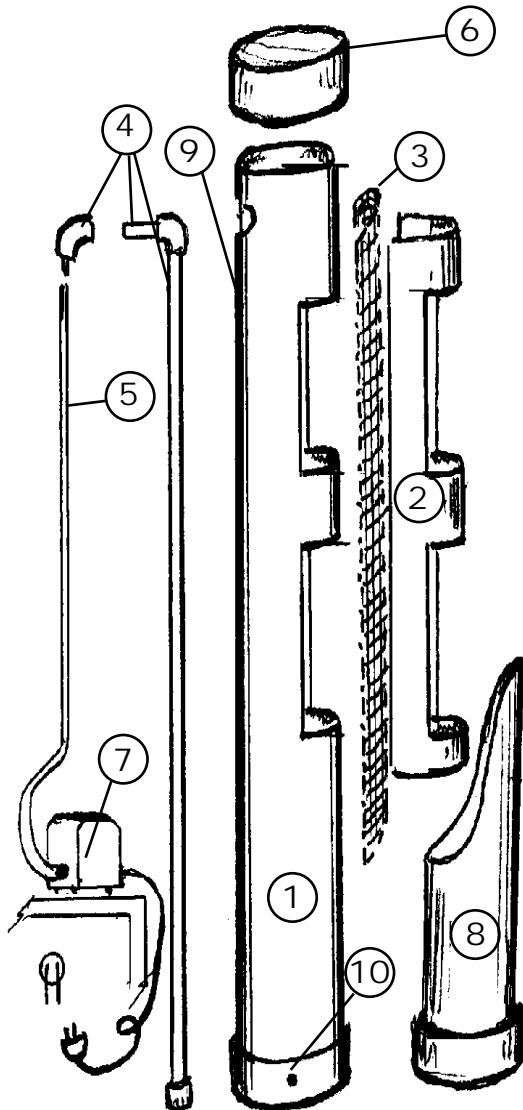

## RECIPES

None of the following recipes are set in stone. We encourage everyone to experiment with different ratios and ingredients but keep in mind the caveat that *if a little is good, more is not necessarily better*. These recipes are just a good place to start.

The most appropriate recipe depends on the crop. Some crops grow better in a bacteria dominated soil while others are more prolific in soil with more fungi. Some plants like more of a balance. Regardless of the ratio of organisms preferred by the target crop, **tea must be made from well-made, mature compost**. High quality tea cannot be made from low quality compost.

Crops like broccoli, cauliflower, cabbage, kale, brussels sprouts, and kohlrabi (cole crops and brassicas) prefer strongly bacterial tea. Whereas trees, shrubs, strawberries, rhododendrons, and vines, like tea with a much higher level of fungi. Most other crops like ideal ranges of both bacteria and fungi but not always an exact balance. Some crops such as tomatoes and most grasses like 25 to 35 percent more bacteria than fungi but fescues, clover, and corn prefer a more even balance. Soil types can also influence the best recipe choice. Grasses, for example, growing in sand typically perform better after applying tea with equivalent amounts of bacteria and fungi but the same plants growing in loam or clay soil prefer a greater percentage of bacteria. Regardless of the type organisms (bacteria or fungi) you are attempting to grow, all of them need trace minerals for metabolic functions. NCO offers *Azomite*, *Feed Grade* to address those needs. Given the infinite number of variables in soils and composts, added to the variations in climate, altitude, and crops, there can be no one recipe that is ideal, which is why we encourage experimentation. Having said that, here's what we suggest:

**BALANCED TEA** has a desirable range of both bacteria and fungi. This tea is appropriate for many different crops. North Country Organics offers *Tea Compost* and a special blend of soluble aerobe foods to feed and grow populations of compost organisms. Tea from our *Tea Compost* can be made more fungal or more bacterial by adding our special boosters that favor one group of organisms over the other. Biological analysis shows that high populations of both bacteria and fungi exist in our *Tea Compost* (analysis available upon request). Use the fill lines on the scoop to determine how much compost to brew. Add one packet of both the *Bacteria Booster* and *Fungi Booster* and one pound of *Azomite*, *Feed Grade* (per 50 gallons of tea).

**BACTERIAL TEA** - Foods—like molasses, fruit pulp and juices, protein—that favor bacterial growth can be added to the brewer to proliferate bacteria but it is difficult to grow large populations of bacteria from a fungal compost. 8 - 16 ounces of molasses or other sugars along with 4 - 8 ounces of pre-dissolved, soluble seaweed, and 1 - 6 ounces of fish emulsion or fish hydrolysate (per 50 gallons of tea) should be added to grow populations of bacteria. Or, try two packets of our special *Bacteria Booster* and one pound of *Azomite*, *Feed Grade* (per 50 gallons of tea).

**FUNGAL TEA** - Add 8 - 16 ounces of pre-dissolved soluble seaweed extract, 8 ounces of fish hydrolysate, and 8 - 16 ounces of pre-dissolved humic acid (per 50 gallons) to grow populations of fungi. Or, try two packets of our *Fungi Booster* and one pound of *Azomite*, *Feed Grade* (per 50 gallons of tea).

**NOTE:** Many food or feed grade materials can be used to enhance compost tea but nothing with preservatives should be added to tea and use only small doses of new ingredients at a time. It's not difficult to ruin an entire batch of tea by adding too many nutrients. Foul smells are the first sign of a tea gone bad.